



# repair manual

Volvo V60

(2011-2018)

---

with motor codes D82PHEV, D87PHEV, D97PHEV and B1APHEV  
**Ajusa reference EV000900**



# content

- 03** General information
- 04** Technical information
- 05** Battery disconnection
- 07** Composition
- 09** Repair
- 11** Additional information



# general information



## WARNING!

### Hybrid vehicle equipped with electric propulsion

This vehicle works with high-voltage electricity which can present **risks of severe or even lethal damages**.



## SAFETY PRECAUTIONS

When working with high-voltage circuits or components, make sure that the **following safety guidelines** are fulfilled:

Make sure all the staff working with the high-voltage systems of electric propulsion have been provided with **proper training** to conduct the necessary procedures.

Put up **high-voltage warning** signs to guarantee the staff safety in the work area.

Make sure that the staff who don't have proper training doesn't have access to any high-voltage circuits and components.

Always wear **insulation gloves** under the related local safety rules.

**Insulate** the high-voltage batteries ensemble.

Before working with the electric propulsion system, make sure that the recommended **waiting time after insulating** the high-voltage batteries ensemble has passed by.

Check that the **residual voltage**, which may be in the circuit, is under the recommended safety level.

Make sure that all **test equipment and tools** are suitable to be used in high-voltage circuits or components.

To **ease the identification**, the high-voltage cabling in the electric propulsion system can be covered by an orange insulation.

# technical information

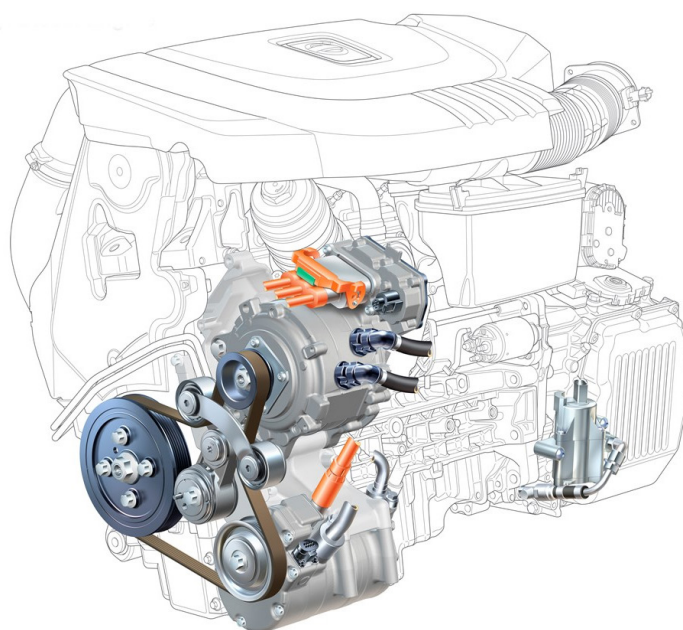

## Types of failure

Insulation failure.  
Problems with the main bearing of the rotor.

## References

Ajusa kit is reference **EV000900**.

Front-wheel drive unit motor with the following OEM references: D82PHEV, D87PHEV, D97PHEV, BIAPHEV

# battery disconnection

## Recommendations to connect and disconnect the battery in electric vehicles

Before getting started it is important to highlight that, in usual inspection and maintenance operations, as well as to disconnect the main battery of the vehicle it **is not necessary to disconnect** the batteries ensemble.

Disconnect the battery only when:

- Replacing the battery.
- In need to reset certain parameters of the vehicle.
- When the car is going to be parked for a long lapse of time, so that the battery doesn't get fully discharged.

## Safety precautions

The batteries ensemble both in electric and hybrid vehicles work with **high voltage**.

- Any worker who doesn't have proper training mustn't have access to any high-voltage circuits and components.
- Always wear suitable personal protective equipment (PPE).

It is essential to put up the related signs to guarantee the safety both of the area and of the workers.

The **batteries ensemble** of the electric vehicle must be insulated at all times to prevent potential short circuits. To insulate and strip the batteries ensemble there are different special tools:

- Tool number 9513038. Insulator tester.
- Tool number 9513049. Hybrid propulsion batteries ensemble insulator connection plug safety cover
- Tool number 9997475. Hybrid propulsion batteries ensemble insulator connection plug safety cover bracket.
- Tool number 9997476. Hybrid propulsion batteries ensemble charging point safety cover.
- Tools number 9513044 and number 9513045. Testing cable adapters
- You must be sure that all the testing devices and equipment are compatible with high-voltage applications.

When the batteries are insulated, a recommended **waiting time must pass** by before proceeding to handling the electric propulsion system.

With the insulation multimeter you will check the residual voltage value in the circuit to be sure that such value is under the recommended value.

The high-voltage cabling in electric vehicles has an orange insulation. Knowing this feature, it is easy to identify it.

## Disconnection/insulation of the electric vehicle batteries ensemble

1) Find the battery. For this step, it is advisable to **look it up in the vehicle's manual**, as the method to reach the battery differs from one vehicle to another.

2) **Start the vehicle** and verify that the instrument cluster works properly and that it doesn't show any warning or failure.

3) It is recommended to **lower the driver's window fully** and slightly the window in the passenger's seat as a safety measure.

4) Check that the gearbox is **neutral** and that the parking brake is activated.

5) Make sure that the power is not connected and the keys are not inside the vehicle. Make sure that all electric components **are off**.

6) Disconnect the vehicle's main battery.

7) Disassemble the **truck floor** cover figure 3.1.

8) **Unlock the insulator** of the hybrid propulsion batteries ensemble figure 3.2 and figure 3.3.

9) Disassemble the insulator of the hybrid propulsion batteries ensemble figure 3.3.

10) Assemble the **safety cover** of the connection plug of the insulator of the hybrid propulsion batteries ensemble figure 3.4. Tool number 9513049. Fix the safety cover of the connection plug of the insulator in its position with the bracket. Tool number 9997475.

11) Assemble the safety cover of the charging point of the hybrid propulsion batteries ensemble figure 3.5. Tool number 19997476. Secure the safety cover of the charging point of the hybrid propulsion batteries ensemble with a lock in order to prevent it from connecting involuntarily.

12) Wait 10 minutes.



Figure 2. Batteries ensemble location

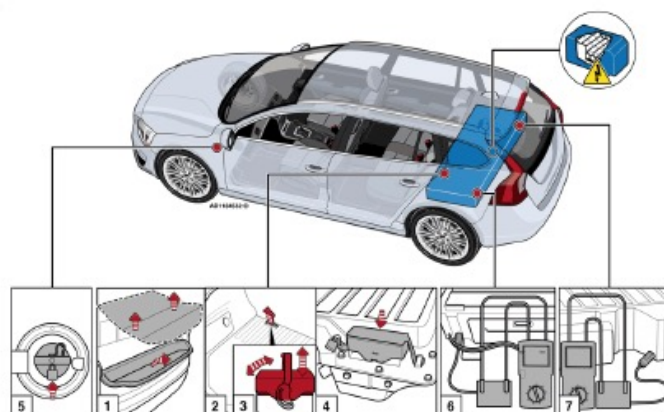

Figure 3. First Responder Loop

## Connection of the batteries ensemble in the electric vehicle

1) Check that the power is not activated and the keys are not inside the car.

2) Undo previous steps.

3) Connect the vehicle's main battery and check that everything works properly.

## WARNING: PREPARATORY OPERATIONS

Confirm that the testing cables are in **good conditions**. Connect the testing meter to a battery 9 V o 12 V to confirm that it works properly. Unplug the hybrid propulsion batteries ensemble plugs. **Check the voltage** in the hybrid propulsion batteries ensemble terminals to make sure the residual voltage in the circuit is below 1 V before starting to work figure 3.6 and figure 3.7. Tools number 9513044 and 9513045..

# composition



**Motor back cover gasket<sup>1</sup>**  
(1 unit)



**Three-phase connections cover gasket<sup>2</sup>**  
(1 unit)

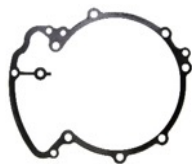

**Motor ensemble cover gasket<sup>3</sup>**  
(1 unit)



**Stator oil seal<sup>4</sup>**  
(1 unit)



**Gears oil seals<sup>5</sup>**  
(2 units)



**O rings**  
(3 units)

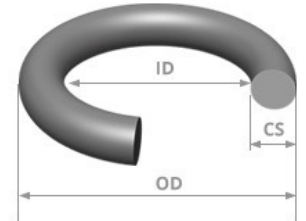

	OD (mm)	ID (mm)	CS (mm)
<b>Differential electronic block gasket<sup>6</sup></b> (1 unit)	40,50	34,50	3
<b>Differential cover gasket<sup>8</sup></b> (1 unit)	184	178	3
<b>Electric plug gasket<sup>9</sup></b> (1 unit)	30,50	25,50	2,5

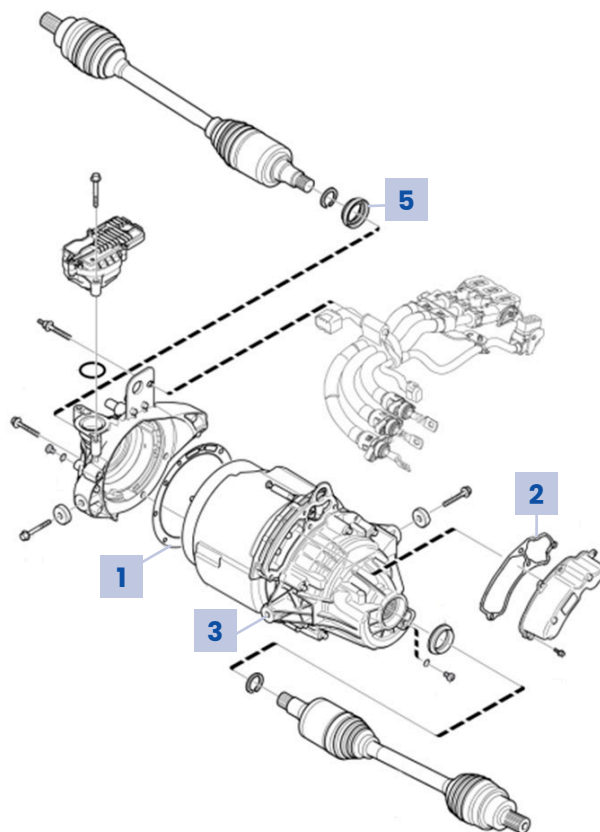



# repair

We will start working for cleaning and opening the transfer gearbox.

## 01



### ***Gear seals***

We will start with the installation of the **gears oils seals<sup>5</sup>** one per side.

## 02

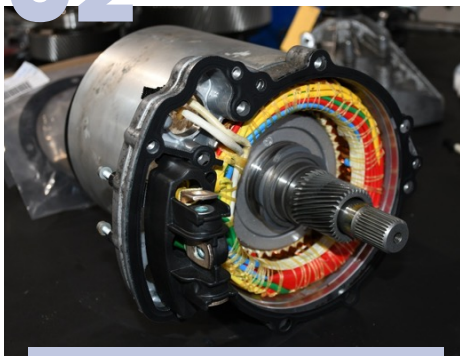

### ***Motor cover gasket***

Once the motor is open, we will continue with the assembly of the **motor ensemble cover gasket<sup>3</sup>**.

## 03



### ***Rotor seal***

Place the rotor seal

## 04

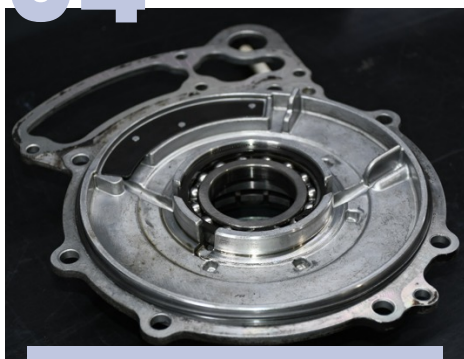

### ***Differential cover gasket***

Once it is placed over the cover, we will place the **differential cover gasket<sup>8</sup>**.

## 05



### ***Assembly***

We will continue with the assembly of the differential group and then we will place the differential cover. We lodge the screws and tighten 20 Nm.

## 06



### ***Motor cover gasket***

Nex step will be placing the **motor back cover gasket<sup>1</sup>** applying a tightening of 20 Nm.

07



**Differential electronic block**

Next step will be assembling the differential electronic block, using the **differential electronic block gasket<sup>6</sup>** and we will conduct a tightening torque of 15 Nm.

08



**Electric plug**

We place the **electric plug gasket<sup>9</sup>** and we will conduct a tightening of 8 Nm.

09

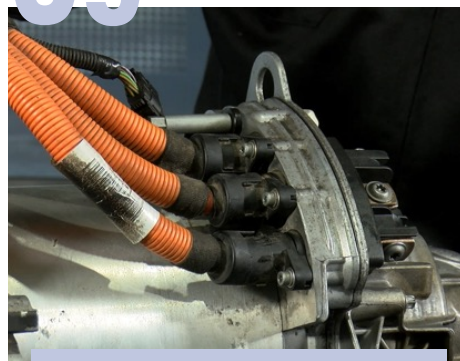

**Three-phase connections**

Then, we continue with the three-phase connections. We apply a tightening torque of 10 Nm to the screws, and of 8 Nm to the cables connectors.

10



**Three-phase connections cover**

Finally, we place the **three-phase connections cover gasket<sup>2</sup>** and we will conduct a tightening of 10 Nm.

11

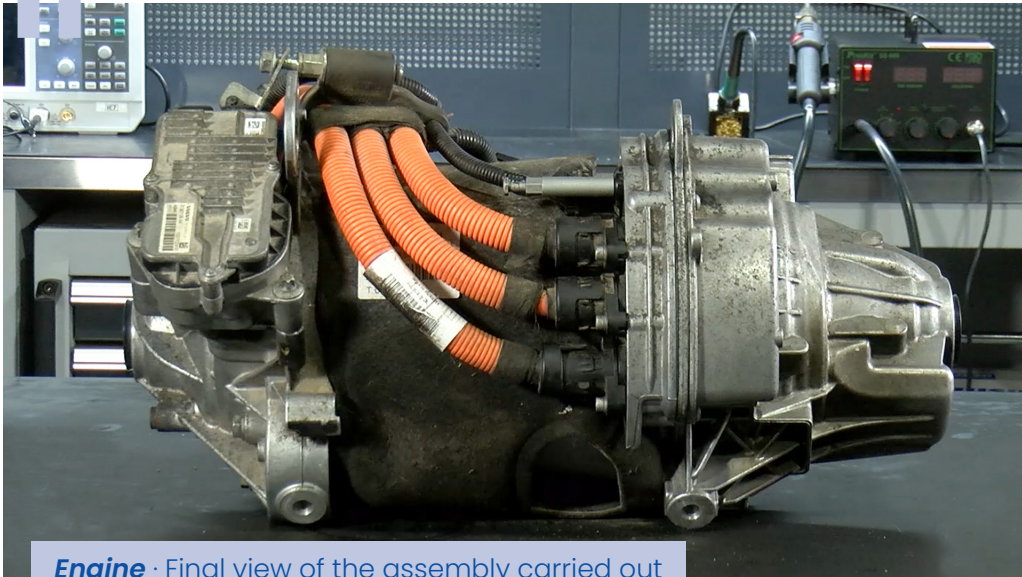

**Engine** · Final view of the assembly carried out

# additional information

Do you know which are **the tools you need** to repair the motor of an electric vehicle? Do you know the **safety measures** to conduct this repair? Is it that you don't know where to start?

Visit the electric vehicle section on our website where we will give you the answers to all these doubts and much more.

You will be able to see the **safety measures video** as well as the **video tutorial** in which you'll see step by step the assembly of the Ajusa kit related to this vehicle.

Furthermore, you can contact our technical assistance department to solve any doubt.

**Subscribe** to our Youtube channel and learn everything you must know about mechanics.



Click here to watch the **assembly video**:

VIDEO